

KUBOTA U17-3

1.8 TONNE

DIMENSIONS & RANGE

Overall Length:	3545mm
Overall Width:	990mm
Overall Height:	2340mm
Overall Weight:	1730kg
Dig Depth:	2310mm

FEATURES



COMPLIANCE



COMPATIBLE WITH

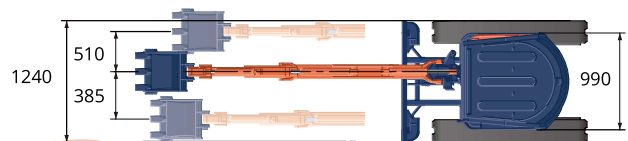
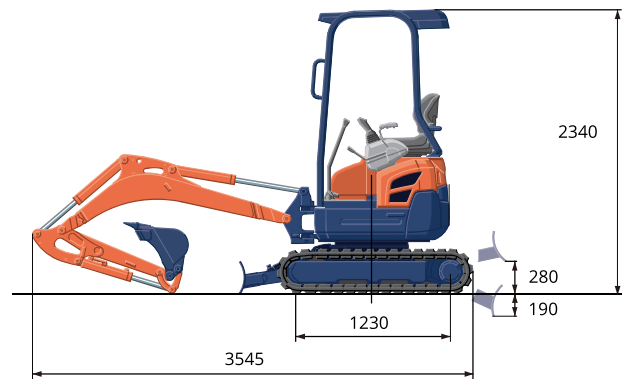

Unit: mm

Victoria's dry hire equipment specialist. We have your equipment needs covered.

7-9 Kearney St., Bayswater, VIC 3153 | Ph: 03 9756 3950 | Email: sales@focusmachinery.com.au | www.FocusMachinery.com.au

YANMAR VI017

1.8 TONNE



DIMENSIONS & RANGE

Overall Length:	3450mm
Overall Height:	2300mm
Overall Weight:	1740kg
Overall Width:	*950 -**1280mm
Dig Depth:	2200mm

FEATURES



COMPLIANCE

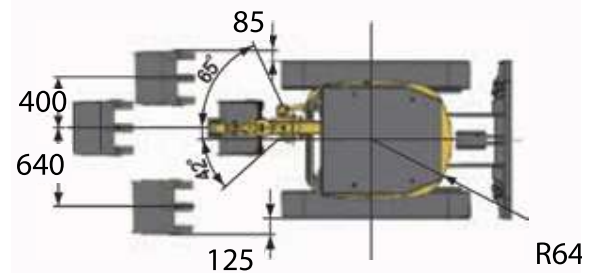

COMPATIBLE WITH

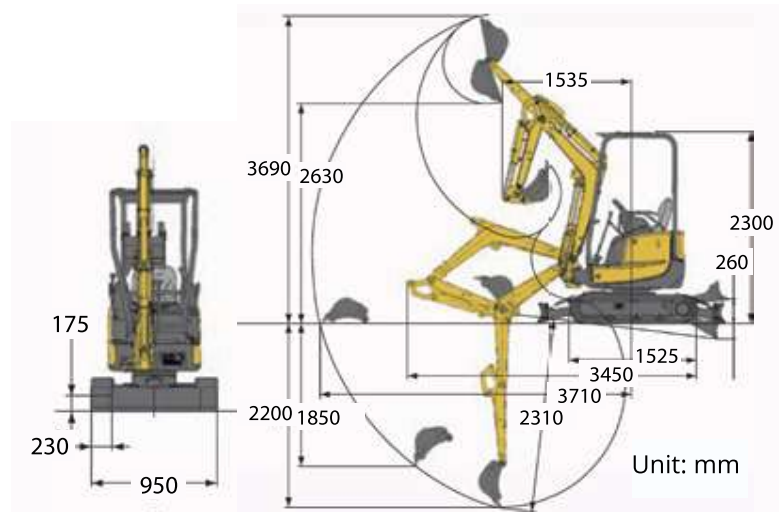
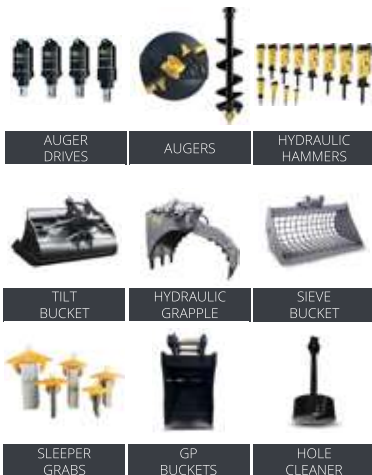

*when retracted **when extended.

Victoria's dry hire equipment specialist. We have your equipment needs covered.

7-9 Kearney St., Bayswater, VIC 3153 | Ph: 03 9756 3950 | Email: sales@focusmachinery.com.au | www.FocusMachinery.com.au