

YANMAR ViO80

8 TONNE



DIMENSIONS & RANGE

Overall Length:	6920mm
Overall Width:	2270mm
Overall Height:	2680mm
Overall Weight:	8225kg
Dig Depth:	4380mm

FEATURES



COMPLIANCE



COMPATIBLE WITH

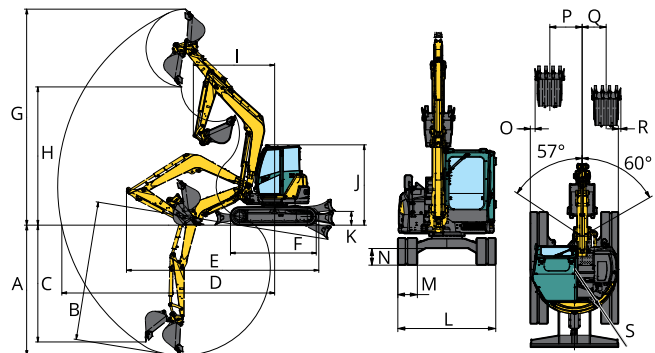

	Rubber Track	Steel Track		Rubber Track	Steel Track
A	4380	4400	K	450	450
B	4670	4710	L	2270	2270
C	3920	3950	M	450	450
D	7280	7280	N	390	380
E	6460	6460	O	120	120
F	2890	2890	P	840	840
G	7250	7250	Q	620	620
H	4640	4610	R	60	30
I	2720	2720	S	1135	1135
J	2690	2680			

Unit: mm

KUBOTA KX080-3*

8 TONNE

DIMENSIONS & RANGE

Overall Length:	6450mm
Overall Width:	2200mm
Overall Height:	2540mm
Overall Weight:	8280kg
Dig Depth:	4600mm

FEATURES

				
SQUAWKER	REFLECTIVE TAPE	EMERGENCY STOP	LOCKABLE ISOLATER	QUICK HITCH
				
UHF RADIO	AIR CONDITIONING	CASE DRAIN	ANTI-DROP VALVES	

COMPLIANCE

					
DAILY CHECKLIST	FIRE EXTINGUISHER	OPERATOR'S MANUAL	PLANT ASSESSMENT	REVERSE BEEPER	ROTATING BEACON

COMPATIBLE WITH

				
AUGER DRIVES	COMPACTION PLATE	COMPACTION WHEEL	GRAPPLE BUCKET	HOLE CLEANER
				
HYDRAULIC HAMMERS	FLIP SCREEN	SIEVE BUCKET	TILT BUCKET	MULCHER
				
DRUM GRINDER	CUTTER CRUSHER	GP BUCKETS	CORE BARRELS	

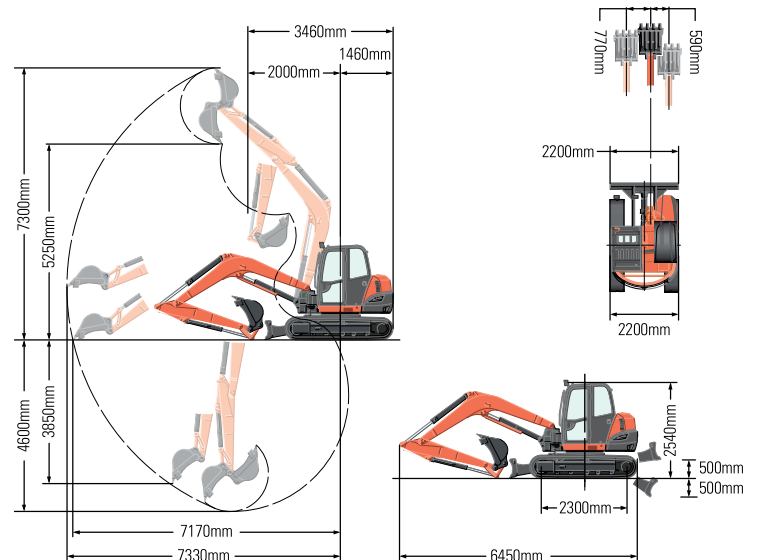

Unit: mm

*Available with Tilt Hitch