

# CASE TR320

90HP



## DIMENSIONS & RANGE

Overall Length:	3611mm
Overall Width:	1930mm
Overall Height:	2043mm
Overall Weight:	4355kg
Ground Clearance:	243mm

## FEATURES



## COMPLIANCE



## COMPATIBLE WITH

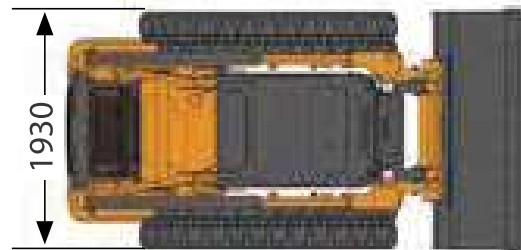
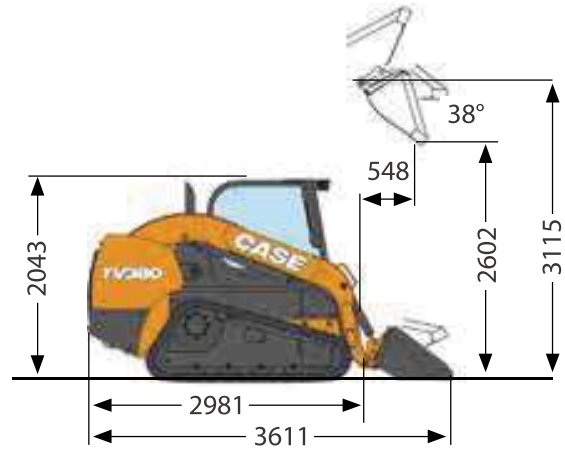
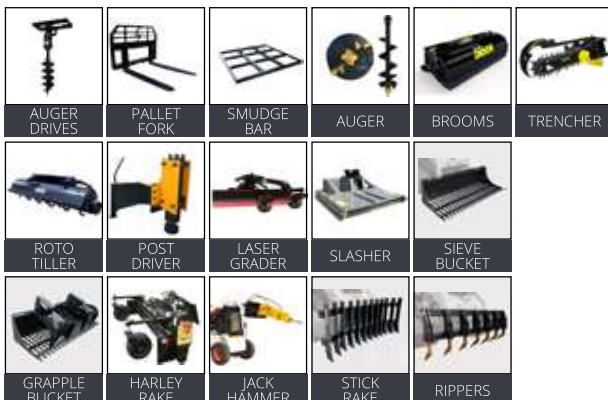

Unit: mm