

# WACKER NEUSON DV60

## DUAL VIEW DUMP TRUCK



### DIMENSIONS & RANGE





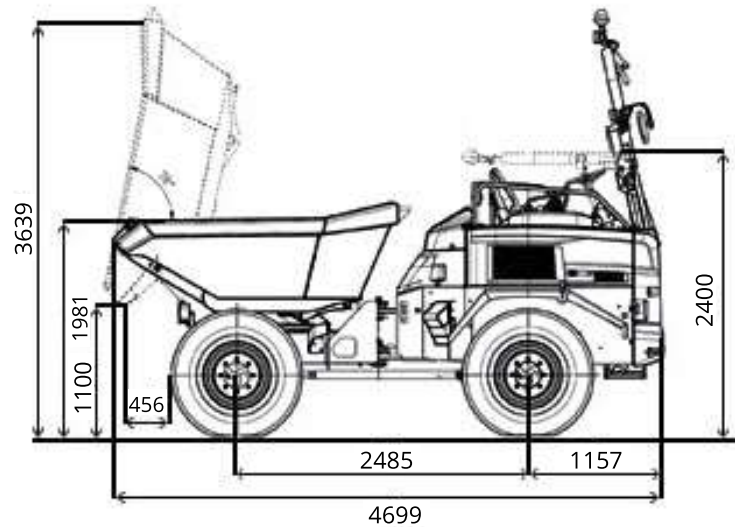

Overall Length:	4699mm
Overall Width:	2230mm
Overall Height:	3377mm
Overall Weight:	6000kg
Carrying Capacity:	3600kg
Volume Capacity:	3.2m <sup>3</sup>

### FEATURES

		
SQUAWKER	REFLECTIVE TAPE	LOCKABLE ISOLATER
		
EMERGENCY STOP	UHF RADIO	AIR CONDITIONING



### COMPLIANCE

		
DAILY CHECKLIST	FIRE EXTINGUISHER	REVERSE BEEPER
		
OPERATOR'S MANUAL	PLANT ASSESSMENT	ROTATING BEACON

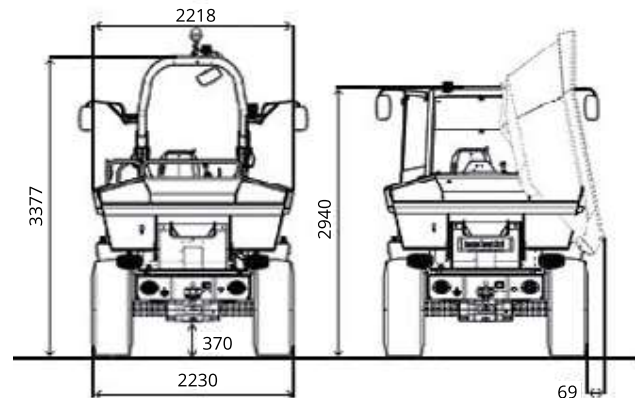

Unit: mm